

Deceptor Pro II Blow-off Valve

Installation Instructions



P.O. Box 1017 Riverwood NSW 2210
Ph: +612 9534 0099 Fax: +612 9534 3999
Website: www.gfb.com.au Email: sales@gfb.com.au

Deceptor Pro II (part # T9533)

Thank you for purchasing the GFB Deceptor Pro II blow off valve. We **highly** recommend that you familiarize yourself with the operation and adjustments of the Deceptor Pro II before installing it.

Installing and wiring the in-car volume controller

- 1) Test the unit before installation by connecting the Deceptor Pro II's plug to the in-car controller. Connect the red wire to the positive terminal of your car's battery or a 12V source. Connect the black wire to the negative terminal. Upon initial power-up, the unit will perform an open/close cycle before reverting to the position indicated on the controller dial. By turning the dial and watching through one of the valve's venting outlets, you will see the inner sleeve move to open or close each of the venting ports alternately, which is how the venting volume is adjusted.

WARNING: Do not manually rotate the noise adjustment, always apply power and use the controller to change the venting bias. When testing your Deceptor Pro II, DO NOT put fingers or foreign objects through the trumpet or plumb back ports. Doing so may result in personal injury or damage to the blow-off valve.

- 2) Find a suitable location on or around the dashboard, steering column or instrument binnacle for your in-car volume controller. Clean both mating surfaces with Methylated Spirits or similar cleaner and secure the controller using the supplied double-sided tape. Press hard and hold the unit for about 30 seconds, and note that it takes up to 24 hours for the tape to develop a strong bond.
- 3) Using a multi-meter or voltmeter, find a suitable power wire that reads 12V only when the ignition is turned on. Solder the end of the volume controller positive (red) wire to the 12V source. It is possible to use a wire tap or crimp instead, but soldering is the most reliable joint. Make sure to insulate the joint properly.
- 4) Find a suitable bolt on the body/chassis and connect the unit's ground (black) wire to it.
- 5) At this point you should plug the Deceptor Pro II back into the in-car volume controller, and test its operation again to ensure the electrical connections are good. Make sure the unit powers on and off with the ignition.
- 6) Unplug the Deceptor Pro II and pass the controller's extension lead through the firewall into the engine bay. Often there is an existing grommet that can be used for this purpose. In any case, it is important to ensure that the lead is protected where it passes through the firewall to prevent wear or damage.

Using the In-Car Controller

When powered up the volume dial rim will glow red, and will brighten for easy reading when you make an adjustment, then automatically dim 3 seconds later to reduce unnecessary glare. The position of the dial is directly proportional the venting bias - turning the dial fully anti-clockwise sets the valve to 100% recirc, fully clockwise results in 100% atmosphere venting, and any proportion is possible between these limits.

The controller also features a program button on the rear of the casing. This can be used to limit the range of the atmosphere-venting bias of the Deceptor Pro II. For example, if you prefer that the maximum atmosphere venting bias is 50%, you can program the controller so that full travel on the dial gives you only 50% movement at the valve. This is particularly useful on cars that through experimentation, find that full atmosphere venting does not agree with them.

To use this feature, set the dial in a position that you want as your maximum atmosphere-venting limit, then press and hold the program button until the dial flashes. The unit will now record this position as the maximum atmosphere-venting limit. Now when you turn the dial fully clockwise, the Deceptor Pro II will only open as far as the point which you have just set. For example, if you pushed the button with the dial set in the middle (50% atmosphere venting), full travel of the dial will now move the valve from full recirc to 50% atmosphere-venting only.

Every time the button is pushed, the position of the dial will determine the maximum venting bias of your Deceptor Pro II. So to re-set the controller to allow the full range again, simply turn the dial fully clockwise and push the button.

Valve Installation

T9533 is suitable for custom hose-mount installations (1.25" I.D. hose inlet and outlet), and is also a direct factory replacement for:

- Mitsubishi Lancer EVO I-X
- Mitsubishi Lancer Ralliart
- Mitsubishi Lancer GSR (4G93)
- Mitsubishi Ralliart Colt

For typical Mitsubishi installations:

1. Locate the factory diverter valve, and if necessary, remove any intercooler hoses in order to gain access to the valve – in most cases this isn't necessary. Loosen the two hose clamps, then pull the valve free from the two large hoses.
2. Open the small hose clip that retains the vacuum hose and slide the vacuum hose off the valve (if it is difficult to remove, try pushing the end of the hose off carefully with a flat screwdriver instead of pulling it).
3. Check the orientation of the factory valve vacuum nipple, and compare it to the GFB valve. The Deceptor Pro II cap can be removed and re-fitted in 4 orientations if required for a better fit.
4. Push the base of the GFB valve (Stealth FX pictured) into the hose so that it is in the same orientation as the factory valve. Then push the plumb back outlet into the turbo intake pipe. Tighten both hose clamps.
5. Re-connect the vacuum hose onto the nipple and replace the hose clip.

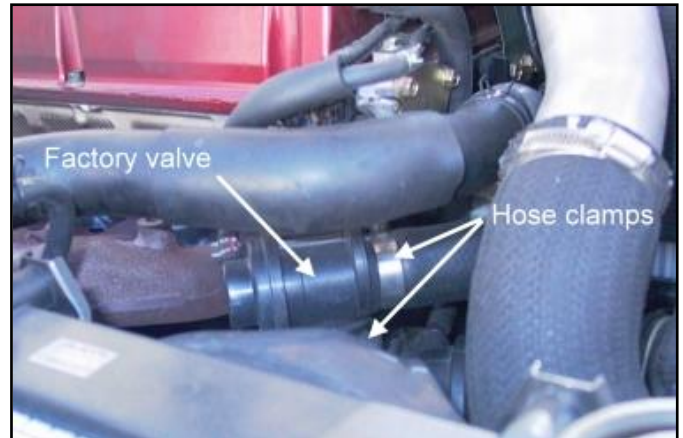

Spring Adjustment

Contrary to popular belief, the spring pre-load **DOES NOT** need to be adjusted to suit different boost levels. The valve will stay shut under full throttle conditions regardless of boost pressure or spring pre-load.

Rather, the spring pre-load affects how easily the valve opens when you lift the throttle, and how long it stays open when it vents. Adjusting the spring is a simple matter of ensuring the valve opens enough to release the air, but not long enough to cause idling problems. The guide below will walk you through the steps involved.

The screw in the centre of the head is the spring adjuster (shown opposite). Use the supplied 5mm hex key for this screw.

The softest spring setting is achieved when the top of the adjustment screw is 3mm above the head of the valve. Do not set the screw more than 3mm above the head.

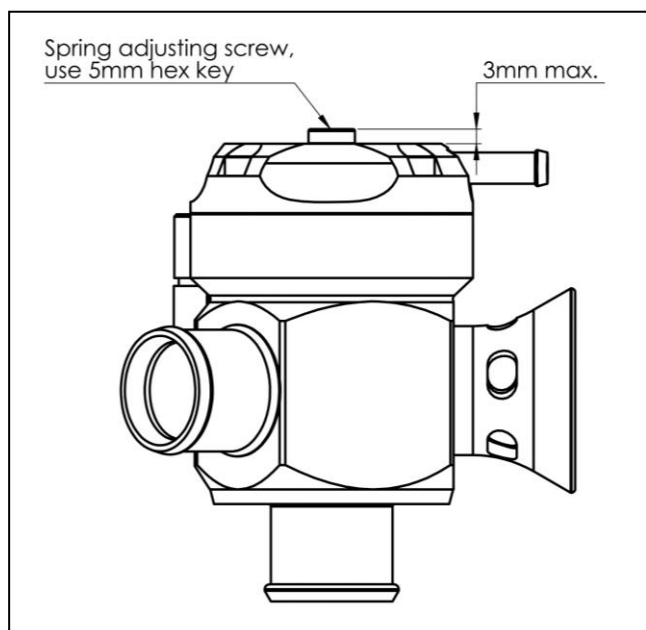

Spring Adjustment – (continued)

- Set the spring to the softest setting, and set the venting bias (via the electronic controller) to at least 50% atmosphere venting so you can see the piston through the trumpet
- Start the car and let it warm up to normal operating temperature. Make sure the A/C is off
- Give the engine a good hard rev, and watch the piston - **WARNING:** Keep your face away from the trumpet opening when revving the engine. View the piston from an angle away from the blast of air. The piston should lift a little and vent with a “whoosh”, then close slowly and smoothly. The harder you stab the throttle, the further the piston will open (note: it will only open fully when driving, as the turbo does not generate significant boost until the engine is under load).
- If the piston stays open too long and does not close before the revs drop back to idle, the engine will “stumble”. If this happens, wind the adjustment screw in the “+” direction one turn at a time until the engine returns smoothly to idle after revving
- For the final fine-tune, take the car for a drive. Watch the tacho as you pull up to a stop - if the revs dip below idle and then rise again, tighten the spring another 1-2 turns
- If a loud flutter is heard when lifting off sharply after accelerating hard above 3500RPM, wind the adjustment screw in the “-“ direction one turn at a time until the noise disappears. Note that it is not uncommon to hear a slight fluttering at low RPM, particularly if you partially spool the turbo and lift off slowly. This is a result of the different way in which this valve operates compared to the factory unit, and is perfectly normal and not detrimental to the turbo

A video example of setting up the spring pre-load can be seen at:

<http://www.youtube.com/watch?v=iqQR5WUF9lc>

Maintenance

GFB blow-off valves are designed to be as maintenance-free as possible. In most cars the small amount of crankcase and rocker-cover oil vapor that is directed into the intake system is enough to keep the piston well lubricated. However, if you notice the sound of the valve changing over time (e.g. slow response time, intermittent operation), or if you can see that the piston is not moving smoothly, it may require a clean and re-lube.

Put a rag under the valve to catch any parts that may drop, or better yet, remove the Deceptor Pro II from the car entirely. Remove the four screws holding on the cap, taking care as the spring will try to push the cap off as the last screw is removed. Remove the spring and the brass piston, and wipe any grime from the inside of the valve and the piston with a rag. Apply normal engine oil to the piston and the inside of the bore, and re-assemble.

Technical Support

If you experience any issues during installation or use of your GFB Deceptor Pro II that are not answered in these instructions, please contact the GFB tech support team on +612 9534 0099, or email support@gfb.com.au.

This product is intended for racing use only, and it is the owner's responsibility to be aware of the legalities of fitting this product in his or her state/territory regarding noise, emissions and vehicle modifications.

GFB products are engineered for best performance, however incorrect use or modification of factory systems may cause damage to or reduce the longevity of the engine/drive-train components.

GFB recommends that only qualified motor engineers fit this product. Warranty is for the period of one year from the date of purchase and is limited only to the repair or replacement of GFB products provided they are used as intended and in accordance with all appropriate warnings and limitations. No other warranty is expressed or implied.